

API Heat Transfer

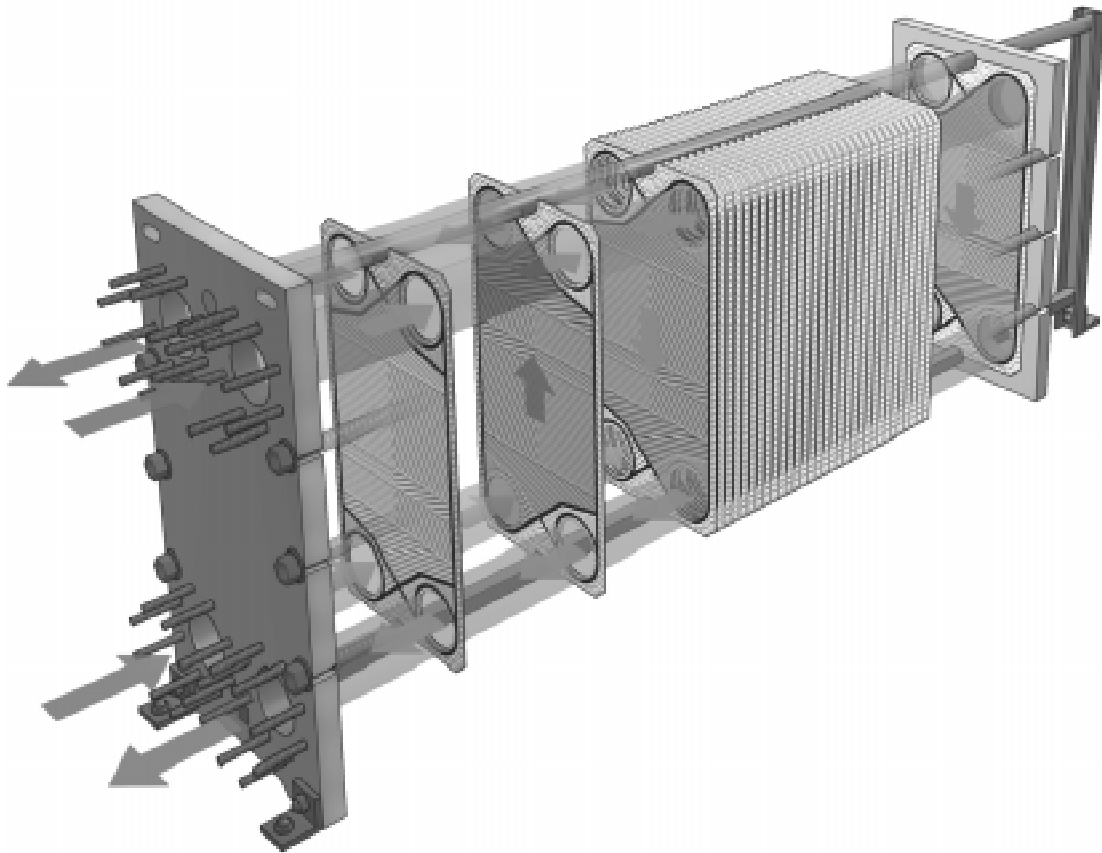

***API Schmidt-Bretten
Plate and Frame Heat Exchanger
Installation and Maintenance Manual***

TABLE OF CONTENTS

<u>Section</u>	<u>Page</u>
1.0 Introduction	3
2.0 Function & Components	3
2.1 Frames	3
2.2 Plates	3
2.3 Gaskets	5
2.4 Flow & Plate Arrangement	5
3.0 Installation Procedures	9
3.1 Lifting	9
3.2 Installation	9
3.3 Piping	11
3.4 Storage	11
4.0 Operating Instructions	12
4.1 General	12
4.2 Start-Up	12
4.3 Shut Down	13
5.0 Maintaining the Exchanger	13
5.1 Opening	13
5.2 Closing	15
5.3 Gasketing	17
6.0 Cleaning the Exchanger	20
6.1 Fouling	20
6.2 Fully Assembled	21
6.3 Disassembled	22
7.0 Problem Solving	23
8.0 Replacement Parts	25
9.0 Unit Specifications	27

1.0 Introduction

API Schmidt-Bretten plate heat exchangers have been installed world wide providing a wide variety of heat transfer solutions using diverse fluids at different temperatures.

The core of the plate heat exchanger is the thin metal corrugated thermal plates that both enhance and conduct heat transfer through them. These thermal plates have an elastomer gasket, confined in a formed groove around the perimeter of the plate, that contains the fluid between the plates. The plates with gaskets are then sequentially installed in to a compact pressure retaining frame that distributes the fluid flow.

2.0 Function & Components

2.1 Frames

- 1 Fixed Pressure Plate
- 2 Movable Pressure Plate
- 3 Upper Carrying Bar
- 4 Lower Carrying Bar
- 5 Support Column
- 6 Roller Bearing Assembly
- 7 Plate Pack Tie Bars

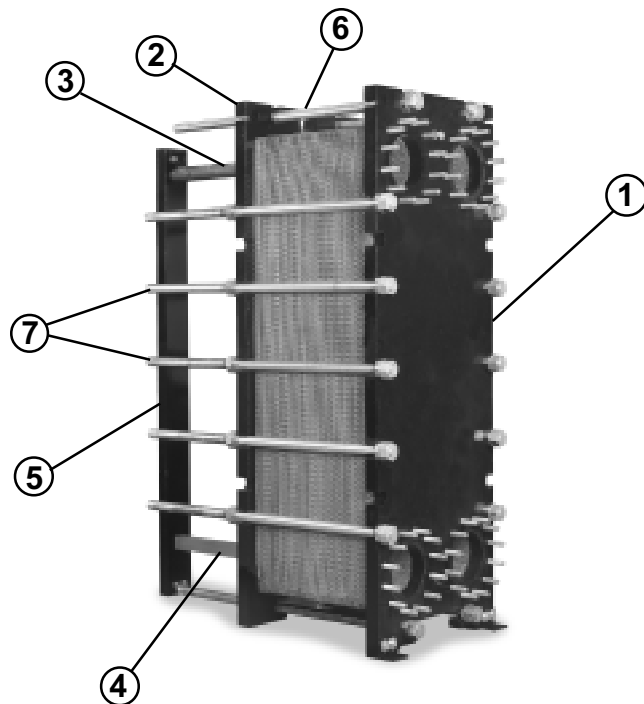

The fixed frame plate (1) and the moveable pressure plate (2) are dense steel plates designed for withstanding high pressures and containing the fluid connections.

The thermal plates are arranged in the frame by hanging from the upper carrying bar (3) and kept in alignment by the lower guide bar (4). The bars are supported by the frame plate in front and in the back by a support column (5) when necessary. A roller bearing assembly (6) is used on larger units for easier maintenance. The tightening bolts (7) bring the thermal plates to metallic contact while compressing the elastomer gasket sufficiently to seal.

2.2 Plates

Depending on the heat transfer solution and the fluids being applied the plate corrugation or surface pattern and its thickness will vary. As the thermal plate's corrugation depth lessens so can it's plate thickness.

API Schmidt-Bretten offers the following surface patterns in a variety of thickness:

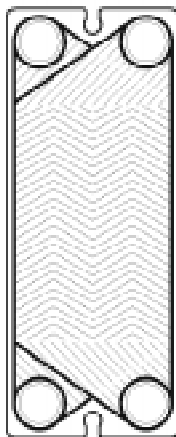

Pattern H

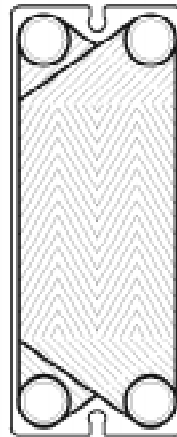

Pattern W

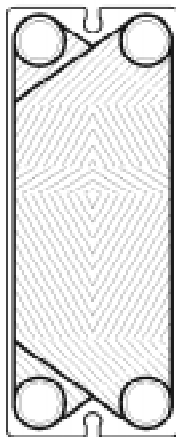

Pattern Y

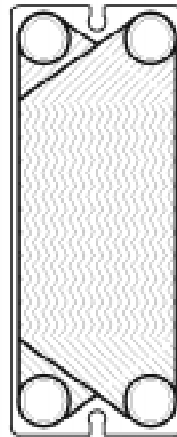

Pattern Z



Pattern F

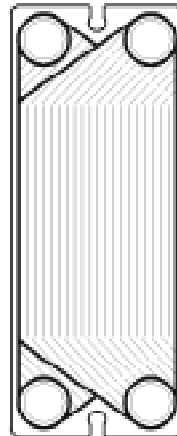

Pattern V

2.3 Gaskets

The gasket that goes between each plate to separate and seal the two fluids is either glued in place or is affixed to the plate using mechanical or a glue free design.

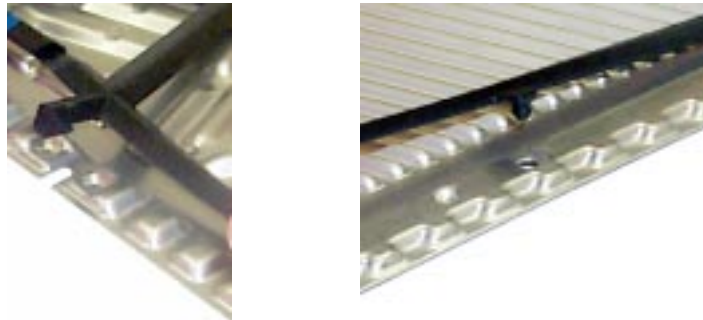

The circular ring portion of the gasket prevents the fluid from going across the thermal plate and sends it on to the next open plate or channel. The remaining field portion of the gasket channels the opposing fluid across the plate / heat transfer surface.

As demonstrated above the two fluids are isolated by the gasket. To prevent possible inter-mixing of the fluids between the ring and field portions of the thermal plate special vents are provided in this unpressurized area.

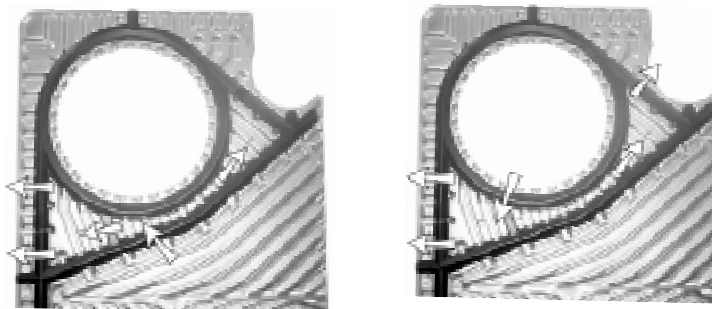

Any fluids escaping from either side will exit the heat exchanger through these vents. These openings must not be plugged as cross contamination of fluids could occur.

With this design any gasket failure will only result in detection on the outside of the heat exchanger and no inter mixing of the two fluids.

2.4 Flow & Plate Arrangement

The plates are arranged in an alternating pattern of “ L “ style (left hand flow) or “ R “ style (right hand flow) to alternate the two opposing fluids in the heat exchanger. The assembly of the thermal plates between the fixed frame plate and the moveable pressure plate is called the “plate pack”.

WARNING!

For proper assembly and sealing of the thermal plates in the plate pack, the plates must be alternated between L and R style. Consequently, the chevron pattern on the plates must alternate between pointing up and down!!

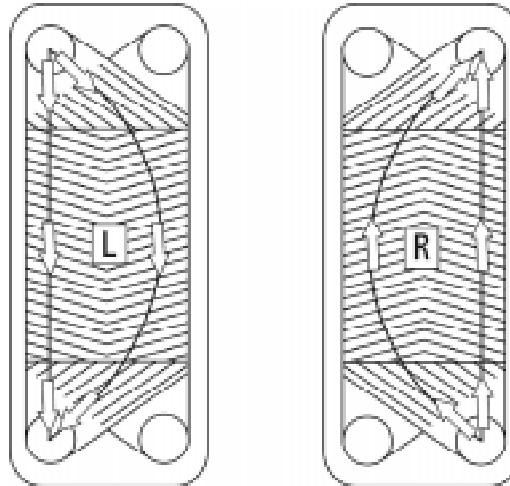

The first or starter plate in a plate pack does not have fluid flowing across it. Instead it has four ring gaskets to seal against the inside of the connections on the fixed frame plate. In this manner, the fluids are diverted to open channels in the plate pack and do not go between the starter plate and the fixed frame plate.

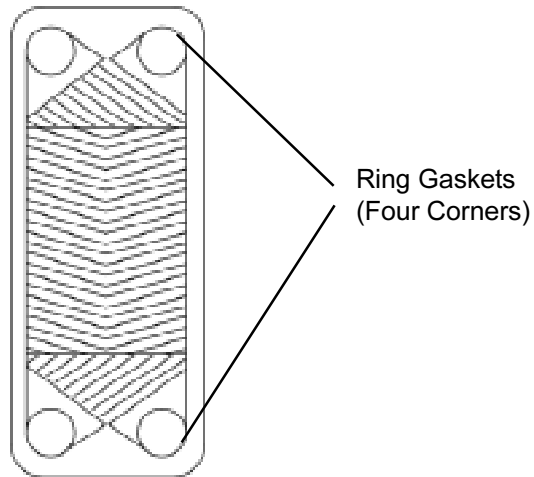

The following are some typical flow arrangements found in plate heat exchangers;

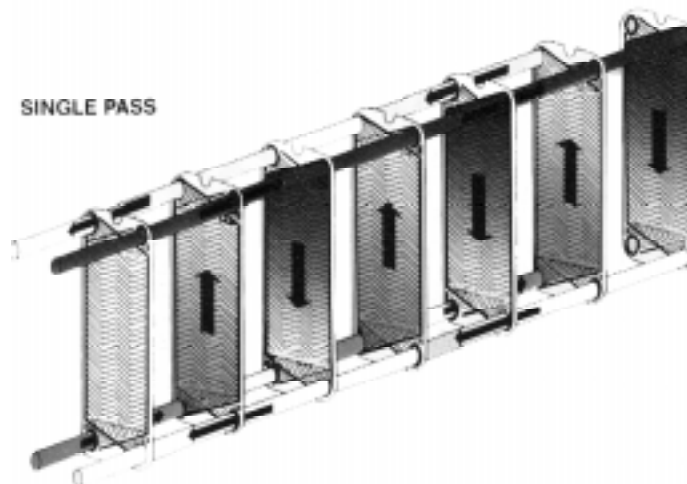

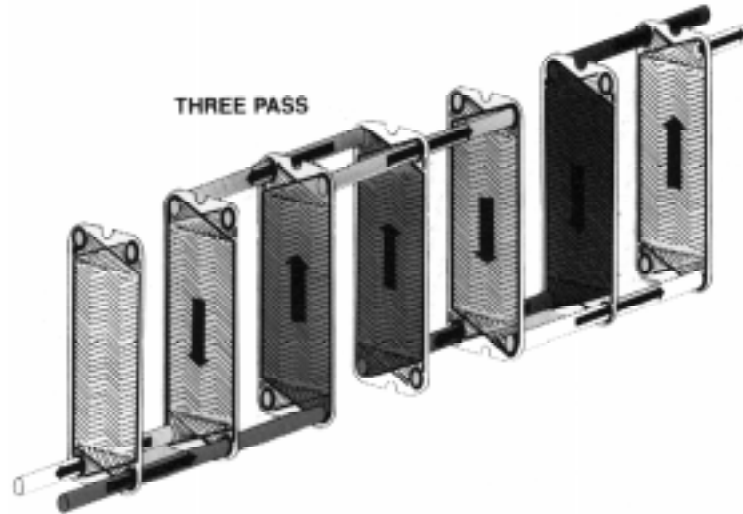

The connection locations may vary for a given plate heat exchanger design. Since all of API Schmidt-Bretten plate heat exchangers are parallel or same side flow, all connections for one fluid will only be on the right side and for the opposing fluid on the left side. The connection locations are defined as follows:

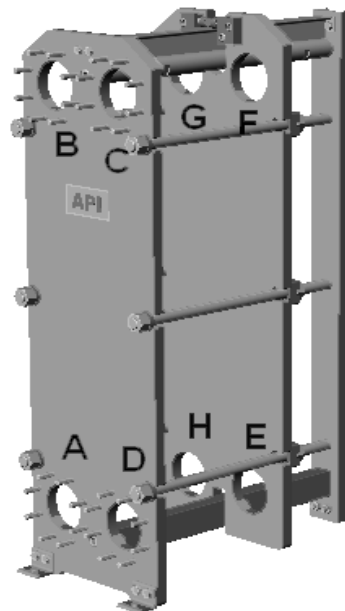

Every API Schmidt-Bretten plate heat exchanger is provided with a plate arrangement drawing showing the proper sequencing and alignment of the thermal plates in the plate pack. The following are some standard rules that must be followed when performing maintenance work on the plate heat exchanger;

- All plates are stamped with an L at one end and an R at the other to assist in proper orientation of the plates.
- Typically the odd number plates (1,3,5,..) are installed with the R at the top and the even number plates (2,4,6,..) with the L at the top to alternate the fluid flow to every other channel.

- The chevron pattern must always be rotated 180 degrees from plate to plate. For example if plates 1,3,5,.. are pointing up then plates 2,4,6,.. should be pointing down.
- The first plate shall be double gasketed as shown on page 6.
- Units with more than one pass require circular ring gaskets to seal between the moveable pressure plate and the back side of the last thermal plate.
- Specially holed plates may be used in accordance with the following figures:

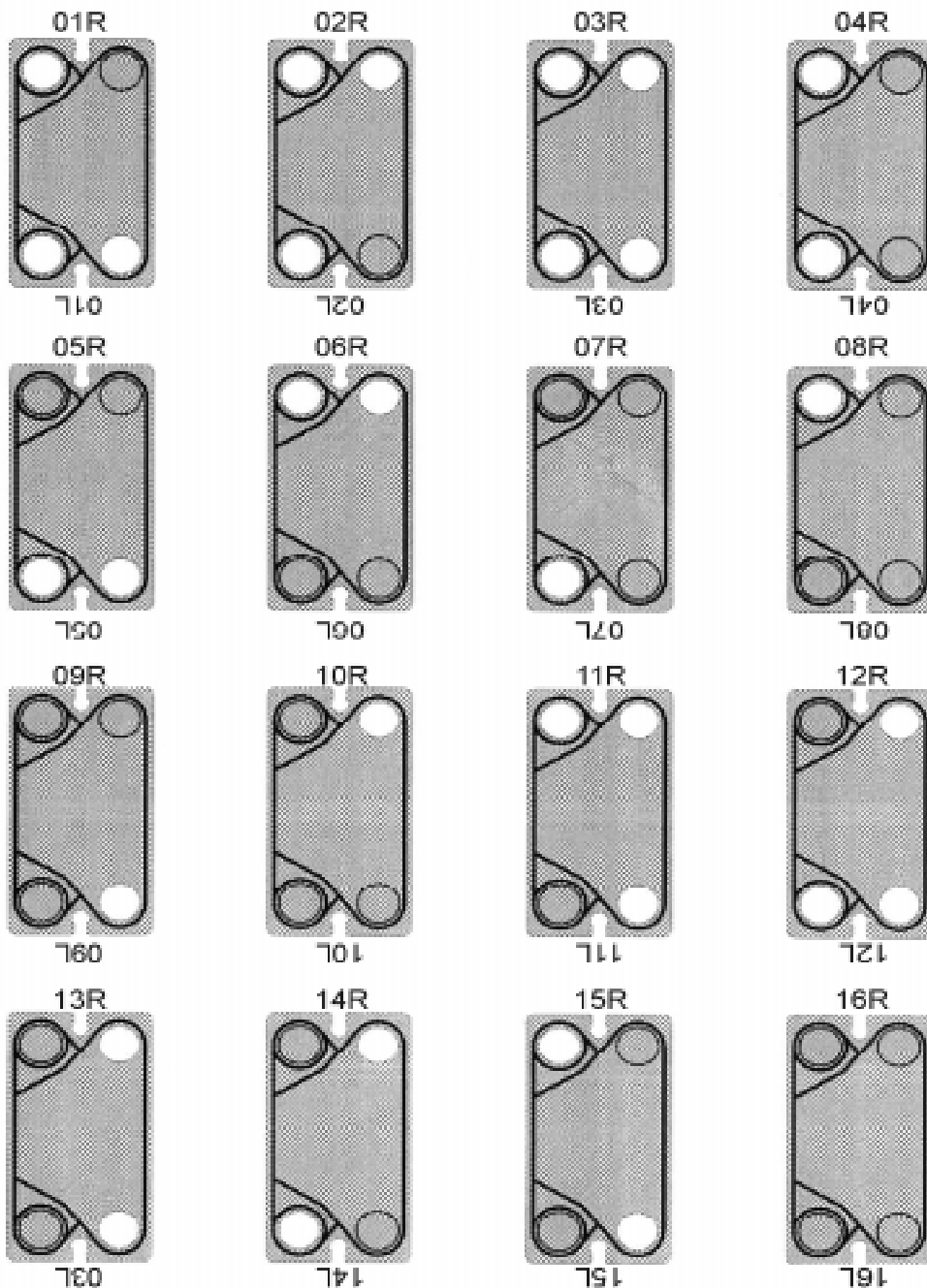

3.0 Installation Procedures

3.1 Lifting

Lifting of the plate heat exchanger shall be done at three points. The lifting cables should go under the top two tightening bolt nuts on the fixed frame plate and around the upper guide bar next to the moveable pressure plate. If lifting holes are provided in either of the header plates, these may be used in a similar fashion.

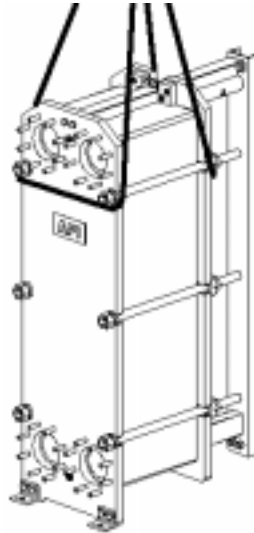

WARNING!

Do not lift the heat exchanger by its connections!!

3.2 Installation

The plate heat exchanger should be installed with approximately 3 feet of open space around it for future maintenance.

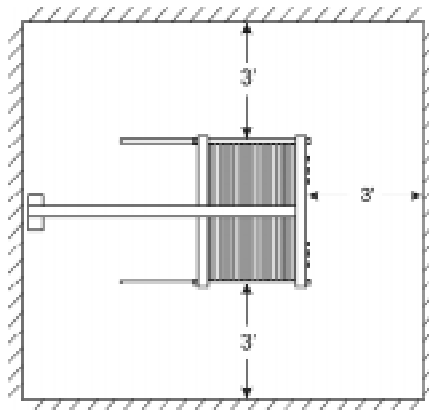

Under special considerations for space, these dimensions may be reduced but servicing the heat exchanger may be compromised.

The heat exchanger must be mounted on a foundation that is level and adequate enough so there is no settling which could cause a strain on the unit and the attached piping.

A liquid retaining trough or drip tray with a volume capacity equal to that of the heat exchanger should be mounted under the plate pack for corrosive services or applications where there is zero tolerance for process fluids being on the floor.

All connections to the plate heat exchanger should be equipped with shut-off valves so the unit may be shut down and opened up without disturbing the entire system. To avoid water hammer, quick action valves should not be used.

For dependable operation avoid sudden pressure and/or temperature surges to the heat exchanger. Provide safety relief valves where the maximum pump discharge pressure may exceed the design pressure of the unit. Pumps should have throttling valves and control valves should be located at the inlets to the heat exchanger. Vibration dampers shall be used on positive displacement pumps and particularly reciprocating pumps.

WARNING!

Sudden fluctuations in pressure or temperature can cause temporary gasket leakage in plate exchangers.

Provide air vents in piping near the high point of the heat exchanger for proper venting and at the low point in the piping for proper drainage.

Prior to installation inspect all the ports of the heat exchanger for foreign debris that could become lodged during operation.

The following are typical connection types used for installing plate heat exchangers.

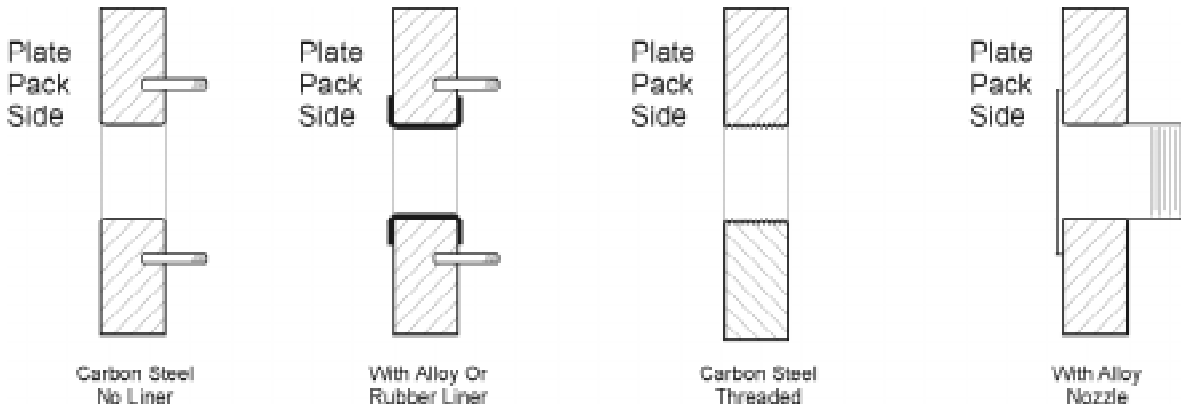

Threaded studs secure the flanges to the fixed frame plate. Alloy or rubber linings are added as necessary to prevent corrosion.

For smaller connection sizes threaded NPT type connections are used.

WARNING!

When installing units with alloy nozzles, the nozzles must be held in place by a wrench to avoid damage.

3.3 Piping

Piping to the plate heat exchanger shall be designed so that it's thermal expansion and weight due not but too much force on the nozzles causing premature failure.

Any forces or moments applied to the nozzles of the plate heat exchanger must be approved by API Schmidt-Bretten.

When a plate heat exchanger has connections on the moveable pressure plate there are special considerations;

- Since the pressure plate is not fixed, it's nozzles can withstand less loading than the nozzles on the frame plate.
- The plate pack may be subject to re-tightening during service therefore when attaching piping to the pressure plate allow for this difference (approximately plus or minus 1% of the final plate pack tightening dimension).

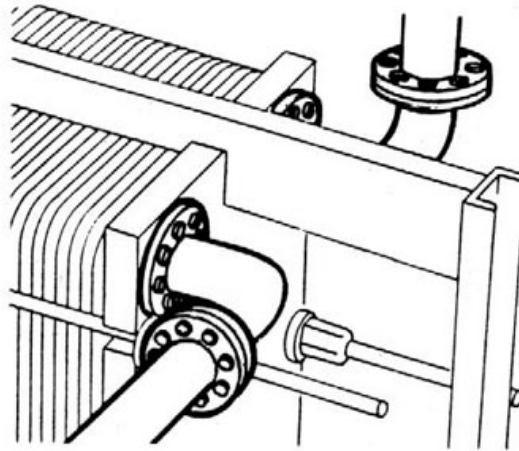

- The pressure plate must move backward for servicing. Use elbowed spool pieces for easy removal.

3.3 Storage

If the plate heat exchanger is to be stored for an extensive time period the following procedure should be used;

- Store at 60-70 degrees F in a closed room.
- Tightening bolts and plate pack should be totally un-tightened.
- Heat exchanger should be totally covered in black plastic.
- Avoid heat, ultraviolet and welding light.
- Apply a rust preventative to all carbon steel machined parts (i.e. bolts, flanged faces....)

4.0 Operating Procedures

4.1 General

The plate pack tightening dimension must be as specified on the nameplate or assembly drawing before operating the plate heat exchanger. Note: If plates have been added or removed to original heat exchanger consult API Schmidt-Bretten for proper tightening dimension. If tightening is required turn to 5.1 Opening & Closing for proper instructions.

WARNING!

Before putting a plate heat exchanger in operation, be certain the entire system is free of sand or particles that will plug the unit during operation.

Check and be certain that the system is set up so it does not exceed the design pressure or temperature of the heat exchanger.

4.2 Start Up

Always start up the plate heat exchanger with the fluid circuit that is at the lower pressure and temperature;

- 1) Close the feed valve located between the pump and the heat exchanger.
- 2) Open fully the shut off valve at the outlet.
- 3) Open the vent valve.
- 4) Start the pump.
- 5) Open the feed valve very slowly.
- 6) When all the air is removed close the vent valve
- 7) Repeat process for the other fluid circuit

Special considerations during start up shall be given when condensing steam in one circuit;

- Never have the steam side on with the liquid side off.
- The steam must always be turned on second and shut off first.
- Steam valves must be set to open gradually to avoid damaging plates.

To prevent shocking the heat exchanger the steam side should be slowly brought up to design conditions by controlled throttling of the cold side fluid.

4.3 Shut Down

- 1) Starting with the fluid circuit at higher temperature and pressure, slowly close the feed valve.
- 2) Turn off the pump.
- 3) Close outlet valve
- 4) Repeat procedure for the other fluid circuit.

For long term storage or maintenance, vent and drain the heat exchanger. Prior to storage flush and or clean the plates to remove any corrosive substances.

Storage procedures are recommended for any heat exchanger that will be out of service for a month or longer..

5.0 Maintaining the Exchanger

5.1 Opening

The plate heat exchanger must be completely shut down and drained in accordance with the previous section before opening.

- 1) If the unit has connections on the pressure plate, the piping must be removed in order to allow it to move freely backward on the carrying bar.
- 2) The carrying bar should be inspected and wiped clean.
- 3) Use a wire brush to clean the threads of the tightening bolts and then lubricate them with a thin layer of molybdenum disulphide or other equivalent grease.
- 4) Carefully remove the safety shield from the unit.

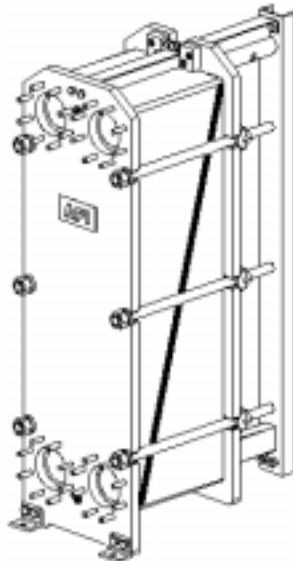

- 5) The plates can either be sequentially marked as they are removed from the unit or a diagonal line can be drawn across plate pack to record each plate's position.

- 6) Record the actual plate tightening dimension "A".

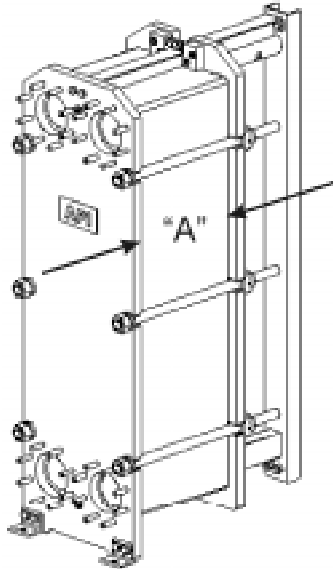

WARNING!

The tightening dimension "A" is critical for proper sealing of the heat exchanger, be certain to record it accurately!!

- 7) If the unit is provided with a lock washer under the nut at the pressure plate, all loosening and tightening can be accomplished from the nut at the frame plate.

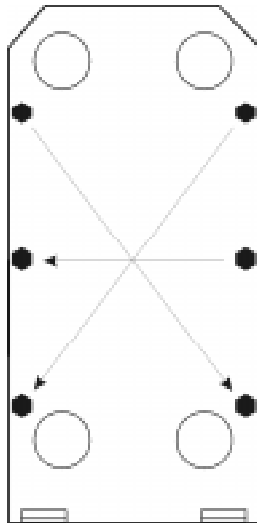

- 8) The heat exchanger can now be opened by loosening opposite diagonally tightening bolt pairs. Loosen each nut only in $\frac{1}{4}$ " to $\frac{1}{2}$ " increments to keep the heads parallel and avoid damaging the heat transfer plates.
- 9) When all the tension is removed from them, the tightening bolts can be taken out, the pressure plate slid back and the thermal plates are now accessible for inspection or removal.

The thermal plates are then removed or installed as follows;

- Move the lower end of the thermal plate diagonally back until it is clear of the guide bar
- Line the upper carrying slot in the plate up with the flattened area in the carrying bar called the assembly slot
- Rotate the thermal plate to an angle that matches the assembly slot
- Either remove or add plates in this manner.

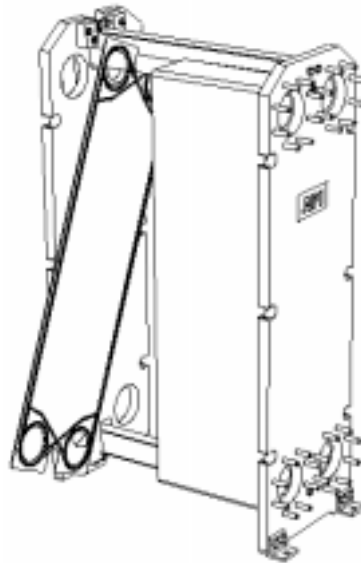

WARNING!

The outer edges of the thermal plates can be very sharp. Wear gloves when handling them to prevent injury!!

5.2 Closing

Additional plates or replacement plates should be installed with the gasketed side facing the frame plate unless otherwise specified.

Before installing plates always consult the plate arrangement drawing for proper sequencing of the plates.

- 1) Install the plates one at a time pushing them forward until they stop.
- 2) Before moving plates forward make certain the gasket is properly secured and that it is clean (wiping of gasket surface may be necessary).
- 3) The sliding surfaces on the carry bar should be cleaned and lubricated.
- 4) If the plate pack was diagonally marked verify the plates are in the proper order before tightening.

- 5) If the plates are assembled in the correct sequence the edges will form this pattern;



- 6) Place the tightening bolts back in position, wire brush them clean and apply a thin layer of grease.
- 7) The plate pack should be tightened alternating between diagonally opposite bolt pairs contrary to the opening procedure. When moving the pressure plate in during tightening, care must be taken to keep the frame and pressure plate parallel to each other by $\frac{1}{4}$ " to $\frac{1}{2}$ ".

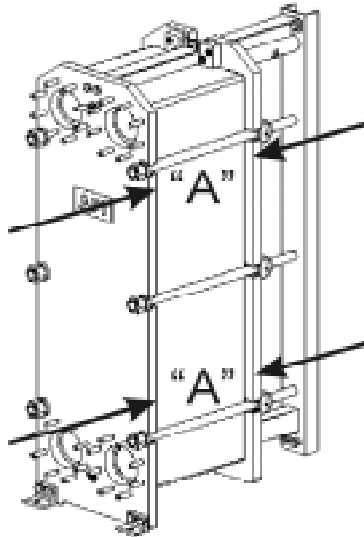

- 8) Continue tightening until the "A" dimension is equal to the maximum tightening dimension given on the nameplate or a new maximum based on the addition or removal of thermal plates.

WARNING!

Do not tighten under the minimum tightening dimension specified for the heat exchanger plate pack as serious damage to the thermal plates can occur.

- 9) All tightening bolts must be under tension.
- 10) When fully tightened the difference between the “A” dimension at adjacent bolts shall not exceed 1/16”. The “A” dimension must not differ by more than 1% between all the tightening bolts.
- 11) If the unit does not initially seal it can be tightened to the minimum dimension specified on the nameplate or provide by API Schmidt-Bretten for a different number of thermal plates. See Warning!
- 12) Replace the safety shield.

Special considerations must given when closing units that have hard compressed fiber gaskets. When closing a unit that has hard gaskets it may be necessary to heat the unit with warm water or product in order to compress the plate pack to the appropriate dimension.

5.3 Gasketing

API Schmidt-Bretten provides **glueless gasket types** for most models. These gaskets are replaced as follows;

- Peel off the old gasket making certain all parts of it are totally removed
- Clean the gasket groove with a cloth making sure no foreign material remains that could disrupt the sealing process
- Attach the new gaskets to the plates using the prongs on the gaskets and attaching them to either the slots or holes provided in the thermal plates.



- Before closing the heat exchanger make sure the gasket and all the prongs are in the proper position
- When the plate heat exchanger is closed and tightened the gaskets provide a tight seal

Many plate heat exchangers utilize a **glued gasket type**. Sometimes these gaskets may be difficult to change and returning them to a qualified service center for replacement may be a wiser choice. Field replacement can be accomplished as follows;

- Old gaskets must be completely removed. A hot air gun or a low torch flame applied to the back of the gasket groove will soften the gasket adhesive allowing the gasket to be pulled off with pliers
- As an alternative plates can be dipped in -196°C liquid Nitrogen which will cause gaskets to crumble off
- The remaining gasket and adhesive in the gasket groove should be removed using a stainless steel scraper or with emery / abrasive paper

WARNING!

Use abrasive paper carefully to avoid creating deep scratches in the gasket groove that could lead to leaks underneath the gasket.

- Afterwards the gasket grooves must be degreased by wiping them with a clean cloth impregnated with a solvent (trilene, tetrachloroethylene, acetone).
- For normal gluing, 3M's type 3MEC1099 adhesive or equal is recommended. Use manufacturer's instructions for best results.

WARNING!

The adhesive must be compatible with the plate and gasket material and the heat exchanger service. Consult supplier if necessary to confirm.

- Adhesive quantity requirements:

<u>Ounces / plate</u>	<u>Models</u>
0.50	S7 - S37
1.00	SX49 - S66
1.50	S108 - S149
- Before applying the adhesive visually inspect the gasket groove making certain it is clean and dry
- Use sand paper or emery cloth to roughen the flat side of the elastomer gasket that will be attached to the plate
- Apply a thin even layer of adhesive to the gasket groove using a short hard brush
- When the glue is tacky, which could take 5-10 minutes, carefully line the gasket up with the groove and press it in
- An elastomer gasket's tolerance may change during and after forming. Short gaskets must be stretched by pulling before installation and long gaskets should have the short ends installed first and then press the gaskets in moving

toward the middle of the plate

- Stack the plates in a pile with a weight on top and allow to dry per the adhesive manufacturer's guideline.

Special consideration must be given to the **endplate gaskets** that seal the first thermal plate against the fixed frame plate and in cases of multipass units the last thermal plate against the moveable pressure plate.

The gasketing on the first thermal plate is made by cutting two standard gaskets and applying them as shown below;

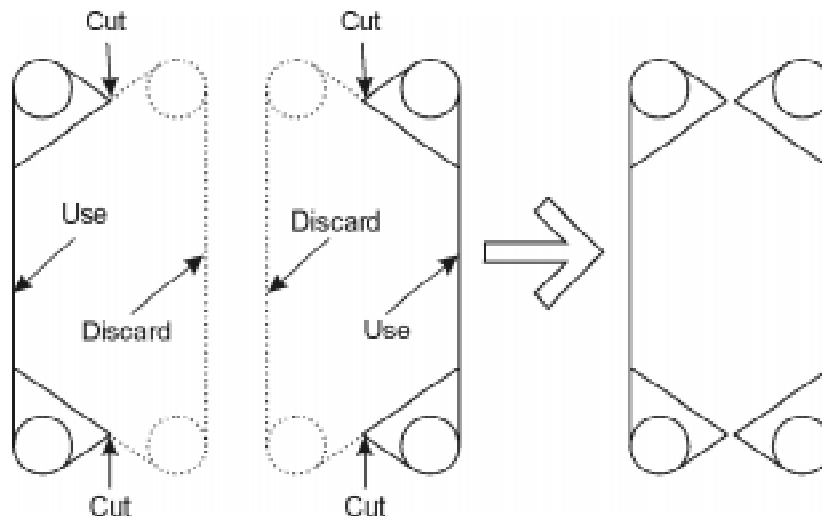

Certain plate models (SX29 & SX49) require a special endplate gasket as shown;

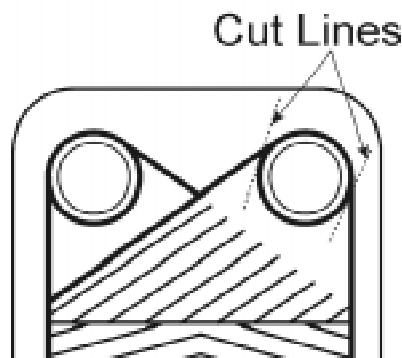

WARNING

In the case of a unit where connections are located on the moveable head, special ring gaskets must be installed on the pressure plate that will seal against the back side of the last heat transfer plate.

6.0 Cleaning the Exchanger

6.1 Fouling

The frequency and type of cleaning required by the plate heat exchanger is dependent on the type of fouling encountered for the specific application.

Fouling can be minimized by increasing the velocity through the heat exchanger at regular time intervals. This reduces fouling by creating larger turbulence that will remove loose scale deposits from the heat transfer surfaces.

When solids may be present in the fluids going through the heat exchanger, it is recommended that a strainer or filter be placed in the pipeline before the heat exchanger to prevent these solids from becoming plugged in the narrow passageways between the heat transfer plates.

Scaling is a common form of fouling in plate heat exchangers. It is caused by high concentrations of calcium, carbonate, calcium, sulphate and silicates in the cooling water. Scaling is removed either by chemically cleaning in place or dismantling and using a soft brush and running water. Chemical cleaning can be done using the following with a maximum concentration of 4% in water and a maximum temperature of 140 degrees F.; Nitric acid, Sulfamic acid, citric acid, phosphoric acid, complexing agents EDTA and NTA and sodium polyphosphates.

WARNING!

Consult and follow manufacturer's instructions when using certain cleaning fluids. Wear eye and skin protection or use a respirator as required.

Biological fouling results from bacteria and other organisms such as protozoa found in the cooling water.

This fouling is removed either by chemically cleaning in place or dismantling and using a soft brush and running water. Chemical cleaning can be done using the following with a maximum concentration of 4% in water and a maximum temperature of 140 degrees F.; sodium hydroxide and sodium carbonate.

Sedimentary fouling consists of metal oxides, corrosion products, silt, alumina and diatomic organisms. Remove sediment in the same way as scaling detailed above.

Residual fouling is hydrocarbon based deposits from oils, asphalt and fats. These are removed by dismantling and cleaning the plates with a soft brush and a paraffinic or naphtha based solvent (i.e. kerosene) followed by rinsing with water. These cleaning compounds can cause damage to elastomer gaskets so exposure to them should be limited to one half hour or less.

Gross fouling or plugging of the heat exchanger can be caused by fibres, assorted solids and seaweed. There is nothing attached to the plate and a strainer before the heat exchanger can usually prevent this type of fouling. Backflushing of the unit may be effective before dismantling of the unit and cleaning the plates with a soft brush is necessary.

WARNING!

Ensure that any cleaning fluid used is compatible with the plate and gasket materials of the heat exchanger. Contact your local cleaning solution provider for recommendations.

Some additional precautions that should be taken to avoid damaging the plate heat exchanger during cleaning;

- Do not use hydrochloric acids for cleaning stainless steel plates
- Using fluids with chloride concentrations greater than 300 ppm can damage the plates
- Ketones, halogenated hydrocarbons, aromatics and esters should not be used as cleaning fluids as they will destroy the gaskets.

6.2 Fully Assembled Cleaning

Backflushing is good method for keeping a heat exchanger in service that is prone to clogging from solids and/or sediment;

- Make provisions in the piping to flow the problem fluid in the opposite direction (backflushing).
- The backflushing should be done with water at 1.5 times the normal flow.
- Problem fluids should normally enter at the bottom of the exchanger and exit at the top so particulate is trapped at the lower portion of the unit and does not make it's way in between the heat transfer plates.
- An alternative backflushing method is to have the ability to reverse both fluids flow direction and to do this periodically.

Cleaning in Place (CIP) is recommended for high fouling applications where frequent cleaning is required. It is especially beneficial for prolonging plate life in highly corrosive applications.

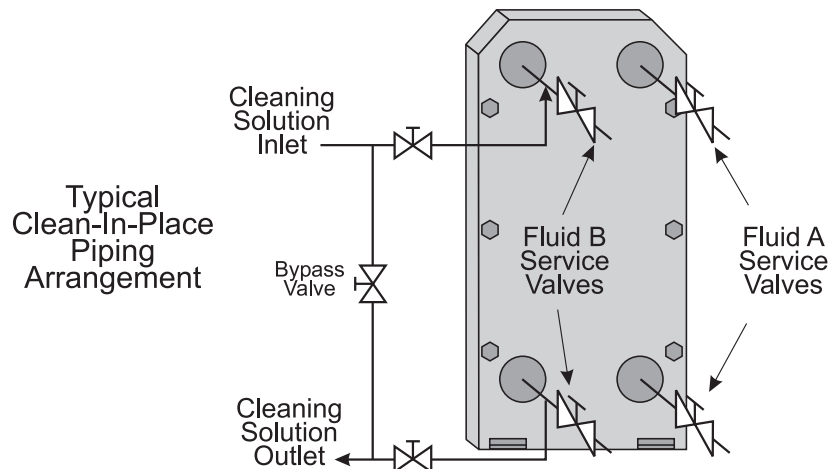

The procedure for Cleaning In Place follows;

- 1) Close all of the isolating valves and drain the exchanger through the CIP system.
- 2) Flush both sides of the unit with warm water (100-120 Deg F) until the effluent water is clear and free of process fluids.
- 3) Completely drain the rinse water from the CIP system.
- 4) Refill the CIP system with water and add the appropriate cleaning solution.

WARNING!

Choice of cleaning solution, time and temperature of cleaning procedure is based on the type of fouling. For best results consult the cleaning fluid supplier.

- 5) Circulate the cleaning solution at 140-180 Deg F for 3-6 hours.
- 6) Drain the cleaning solution from the CIP system and flush the unit again with warm water following steps two and three.
- 7) Close the valves to the CIP system and reopen the main isolating valves to the heat exchanger.
- 8) "Start Up" the heat exchanger as prescribed in section 4.2.

6.3 Disassembled Cleaning

Many time CIP will not be effective and the plate heat exchanger must be dismantled to be cleaned. For manual cleaning proceed as follows;

- 1) Open the heat exchanger as indicated in section 5.1.
- 2) Slide the plates apart to allow for possible cleaning by a soft brush or water rinsing while they remain in the frame.
- 3) When using a water jet to clean the plates they must be placed on a flat surface and the jet spray directed away from the gaskets to avoid damaging them.
- 4) Do not use a steel brush or steel wool for cleaning the plates as damage to them can occur.
- 5) Be careful not to scratch the gasket surfaces.
- 6) Use the appropriate cleaning solution for the type of fouling 6.1 and Warning! note above.
- 7) Apply the cleaning solution to the plates and let stand as necessary . Brush and rinse. If necessary repeat the process.
- 8) After final brushing rinse well with water and then wipe dry.
- 9) Inspect all parts before reassembling per section 5.2.

7.0 Problem Solving

The following is a guide to trouble shooting the plate heat exchanger. If more assistance is required please contact API Schmidt-Bretten personnel.

Condition: Fluid leak between the thermal plates to the outside.

Cause: A loose or damaged gasket

Solution: Note which plate is leaking and open the heat exchanger in accordance with section 5.1 and examine the gasket to see if it has become dislodged from it's gasket groove or suffered damage. Reposition or replace the gasket as necessary.

Cause: The plate heat exchanger is not fully tightened.

Solution: Verify that the number of plates in the heat exchanger matches the drawings. Note the maximum and minimum tightening dimension of the heat exchanger from the nameplate or the drawing. Tighten the heat exchanger in accordance with section 5.2 until the leak stops.

WARNING!

Do not tighten the heat exchanger below the minimum tightening dimension as damage to the heat transfer plates will occur. Consult the factory for proper tightening dimension if necessary.

Cause: A thermal plate has been damaged due to over tightening or physical abuse.

Solution: Typically a damaged plate must be removed from the heat exchanger and either repaired or replaced. Note which plate is leaking and open the heat exchanger in accordance with section 5.1. Remove the damaged plate and replace it with a new one.

If a replacement plate is not readily available, the unit may be made operable as follows; 1) Remove the damage plate, 2) If the plate is a standard four hole heat transfer plate, remove the plate immediately preceding or following the damaged plate, 3) Close the heat exchanger in accordance with section 5.2, 4) The heat exchanger must be tightened to a new reduced tightening dimension due to the removal of the two plates. Consult the factory for the proper new one.

Cause: A thermal plate is misaligned in the plate pack.

Solution: Remove the leaking plate and repair the plate hanging area so the plate hangs and alligns properly in the plate pack. If the plate still does not hang properly then it must be replace with a new one. Close heat exchanger in accordance with section 5.2.

Condition: Fluid leak between the thermal plate and the fixed frame plate or moveable pressure plate.

Cause: The gasket may have become dislodged, foreign material could be under the gasket or the gasket sealing surface could have deep scratches or other damage.

Solution: Open the plate heat exchanger in accordance with section 5.1. Check the sealing surfaces on the frame plate for any irregularities or foreign materials that could create gasket sealing problems. Make the necessary corrections and make certain the gasket is in the proper location on the thermal plate. Close and tighten the heat exchanger in accordance with section 5.2.

Condition: Fluid leaks on the outside of the frame where the external piping is joined to the frame.

Cause: The sealing gasket between the frame and the mating flange may have become dislocated or damaged.

In some cases the alloy nozzle lining or stub end may have suffered damage from excessive nozzle loading or corrosion.

Solution: The piping to the heat exchanger must be disconnected and removed.

If the sealing gasket appears to be out of place or damaged simply replace the gasket, making certain no foreign debris is present to interfere with the sealing process. Then reconnect and tighten the piping.

With the piping removed, the alloy nozzle lining or stub end should be visibly examined for any sign of cracks or other damage that could indicate a leak. If damage is suspected, the unit should be disassembled in accordance with section 5.1. The lining or stub end can now be examined by dye penetrant testing for leaks. Damaged parts should either be repaired or replaced and then close the unit in accordance with section 5.2.

Condition: Fluid from one side of the heat exchanger leaks in to the other side

Cause: If the piping is connected to the heat exchanger at the wrong locations, immediate cross contamination or mixing of the fluids will occur. The most probable cause is the presence of holes in the thermal plates due to corrosion.

Solution: Make certain the piping is correctly connected to the heat exchanger.

Disconnect the piping on one lower connection of the heat exchanger. By pressurizing the remaining connected side a cross contamination leak will be indicated by fluid leaking in to the opened lower connection/port area. If there is no leak then the contamination is occurring away from the heat exchanger. If there is a leak, record which plate is leaking and open the heat exchanger in accordance with section 5.1.

Remove the thermal plates and examine the ones closest to the leak to see if you can observe any perforations in the plates. It is also important to observe the leak detector grooves in the gaskets; if deposits have gathered in these grooves and closed them off it is possible for a fluid to migrate from one side of the exchanger to the other. For easier detection of perforations a magnifying glass, dye penetrant testing or a bright light behind the plates may be used.

Perforated plates are not repairable and must be replaced.

If necessary the heat exchanger can be put back in service with fewer plates, see "Fluid leak between the thermal plates to the outside".

Condition: The pressure drop across the heat exchanger is higher than predicted.

Cause: The thermal plates may have become blocked with debris/scaling or the plates may be installed wrong.

Solution: Accurately measure the pressure drop across the heat exchanger. Examine the outer edge of the plate pack and be certain the outer edges of the plates form a checkered pattern indicating that all plates are installed in the proper direction.

If possible attempt to backflush the heat exchanger at a high velocity to dislodge any trapped debris. If this is not successful or available the unit must be cleaned in accordance with section 6.3 disassembled cleaning.

Condition: The heat transfer capacity of the heat exchanger is declining.

Cause: The thermal plates are becoming fouled during operation.

Solution: Follow sections 6.2 and 6.3 for procedures for cleaning the heat exchanger.



8.0 Replacement Parts

API Schmidt-Bretten Parts Order Form

To: API Schmidt-Bretten

Date:

Fax: 716-684-2129

Number Pages: _____

Attn: _____

Purchase Order Number: _____

For best service telefax this spare parts order form to API Schmidt-Bretten at 716-861-1125.

For telephone questions call 718-684-6700.

When ordering or requesting replacement parts the following information is required:

Heat Exchanger Model: _____

Serial Number: _____

Part Number: _____

Complete Plate Pack: Yes No

Complete Gasket Set: Yes No

If individual thermal plates are required and the above information is unknown, the following information must be provided for each new thermal plate required:

Heat Exchanger Model: _____

Plate Material: _____

Plate Thickness: _____

Plate Style (Page 4): _____

Gasket Material: _____

Glueless Gasket Yes No

Plate Punching, (Page 8) _____

First thermal plate Yes No

The above information is critical in providing the proper replacement parts.

9.0 Unit Specifications

Exchanger Model: _____

Exchanger Serial Number: _____

Exchanger Part Number: _____

Design Pressure and Temperature: _____

Bill of Material: _____

Plate Material / Thickness: _____

Number of Plates and Style: _____

Number of Gaskets and Material: _____

Frame / Pressure Plate Material: _____

Connection Material, Hot Side: _____

Connection Material, Cold Side: _____

Service of Unit: _____

Notes: _____

API Heat Transfer

API Heat Transfer, Inc.
2777 Walden Avenue
Buffalo, NY 14225

API Airtech Inc. ISO-9001 Certified

Air Cooled Aluminum Heat Exchangers

91 North Street • P.O. Box 68
Arcade, New York 14009-0068

(716) 496-5755 • Fax: (716) 496-5776

API Basco Inc. ISO-9001 Certified

Basco/Whitlock Shell & Tube Heat Exchangers

2777 Walden Avenue
Buffalo, New York 14225

(716) 684-6700 • Fax: (716) 684-2129

API Ketema Inc.

Basco/Whitlock Shell & Tube Heat Exchangers

Acme® Refrigeration Equipment

2300 West Marshall Drive
Grand Prairie, Texas 75051

(972) 647-2626 • Fax: (972) 641-1518

www.apiketema.com

API Schmidt-Bretten Inc.

Plate Heat Exchangers

2777 Walden Avenue
Buffalo, New York 14225

(716) 684-6700 • Fax: (716) 684-2129

API Schmidt-Bretten GmbH.

ISO-9001 Certified

Plate Heat Exchangers

P.O. Box 1580 D-75005 Bretten

Pforzheimer Strasse 46

D-75015 Bretten, Germany

7252/53-101 • Fax: 7252/53-201

Call your local API Sales Representative or API
directly toll-free at 1-877-API HEAT.

Visit us at www.apiheattransfer.com

Other Products Available from API Heat Transfer

OptiDesign®



Straight-tube, removable bundle exchangers made from standard components. Floating tube sheet for seal leak detection and easy maintenance. Diameters from 3" (7.62 cm) to 42" (106.68 cm). ASME, API, TEMA, ABS and other codes available.

Pipeline Aftercoolers



Straight tube, counterflow aftercoolers designed to yield cool, dry compressed air. Available with or without accompanying moisture separators and constructed to a wide variety of design codes. Diameters from 6" (15.24 cm) to 42" (106.68 cm).

TEMA Shell and Tube



A wide variety of TEMA types are available using pre-engineered or custom designs in various sizes and materials. Shell diameters from 6" (15.24 cm) to 60" (152.4 cm), ASME, TEMA, API, ABS, TUV, ISPEL and other code constructions available.

Refrigerant Evaporators & Condensers



Off-the-shelf, standard units reflect the latest in heat exchanger technology for maximum performance and low cost. Ideal for OEM or aftermarket applications. Numerous design and material options are available. Tonnage capacity ranges from 5 to over 400 tons.

Extended Surface



Unique, patented plate-fin design for centrifugal or axial compressor intercooler and aftercooler applications and minimal pressure loss. Design eliminates separators. ASME code design is standard. Diameters from 20" (50.8 cm) to 120" (304.8 cm).

Air-Cooled Heat Exchangers



High efficiency, brazed aluminum coolers for cooling a wide variety of liquids and gases with ambient air. Lightweight, yet rugged. Capable of cooling multiple fluids in single unit. Models can be supplied with cooling fan and a variety of drives.

Plate Heat Exchangers



Compact units provide excellent heat transfer and small size. Plates are pressed from stainless steel, titanium and other alloys. Gaskets of nitrile, EPDM, Viton®, compressed fiber and Teflon® are used. Gasket-free welded and brazed designs available.

ACME® Packaged Chillers



Packaged chillers with or without pumping systems from 3 to over 400 tons with PLC controls available. Standard and custom designed chiller-barrels and condensers to 2,500 tons with same-day shipment on many units. DX and flooded evaporators available.